

METRO FLOOD DIVERSION AUTHORITY

Thursday, January 26, 2017

3:30 PM

Fargo City Commission Room

Fargo City Hall

200 3rd Street North

1. Call to order
2. Approve minutes from previous meeting Item 2. Action
3. Approve order of agenda Action
4. Management Information
 - a. PMC report
5. Administrative/Legal Information/action
 - a. Admissibility Agreement – MDNR Working Group
 - b. Executive Director Position Description Item 5b.
6. Finance Information/action
 - a. Committee report Item 6a.
 - b. Voucher approval Item 6b.
 - c. Recommended contracting actions Item 6c.
7. Other Business
8. Executive Session (if needed)

Meet in executive session pursuant to N.D.C.C. §44-04-19 through §44-04-19.2 for the purpose of attorney client consultation and update regarding matters arising out of or related to the on-going litigation matter of the Richland/Wilkin County Joint Powers Authority v. Army Corps of Engineers and the City of Oxbow as intervenors and to receive legal advice regarding the Minnesota DNR's decision to deny the Dam Safety and Public Waters Work Permit Application submitted by the Metro Flood Diversion Authority

9. Next Meeting – February 9, 2017

10. Adjournment

cc: Local Media

**METRO FLOOD DIVERSION AUTHORITY
JANUARY 12, 2017—3:30 PM**

1. MEETING TO ORDER

A meeting of the Metro Flood Diversion Authority was held Thursday, January 12, 2017, at 3:30 PM in the Fargo City Commission Room with the following members present: Fargo City Mayor Tim Mahoney; Fargo City Commissioner Tony Grindberg; Fargo City Commissioner Dave Piepkorn; Cass County Commission representative Darrell Vanyo via conference call; Cass County Commissioner Mary Scherling; Cass County Commissioner Arland Rasmussen; Moorhead City Mayor Del Rae Williams; Moorhead City Council Member Chuck Hendrickson; Moorhead City Council Member Joel Paulsen; Clay County Commissioner Kevin Campbell; Clay County Commissioner Grant Weyland; Cass County Joint Water Resource District Manager Roger Olson; and West Fargo City Commissioner Mike Thorstad.

2. NOMINATION OF VICE CHAIR

MOTION, passed

Mr. Grindberg moved and Mr. Campbell seconded to nominate Del Rae Williams, Moorhead City Mayor, as Vice Chair of the Metro Flood Diversion Authority. Motion carried.

3. DESIGNATION OF SECRETARY

MOTION, passed

Mrs. Scherling moved and Mr. Olson seconded to designate Heather Worden as the Secretary of the Metro Flood Diversion Authority. Motion carried.

4. MINUTES APPROVED

MOTION, passed

Mr. Weyland moved and Mr. Campbell seconded to approve the minutes from the December 15, 2016, meeting as presented. Motion carried.

5. AGENDA ORDER

MOTION, passed

Mr. Grindberg moved and Mr. Weyland seconded to approve the order of the agenda. Motion carried.

6. MANAGEMENT UPDATE

Program management consultant (PMC) report

Randy Richardson from CH2M provided an update on activities over the last month including the release of the Public Private Partnership (P3) Request for Proposals (RFP) to the four short-listed proposers; approval of the FY 2017 annual budget; Phase 1 land acquisition and opportunistic land acquisitions; contract award for the Oxbow home demolition package; continued outreach and coordination with the MN DNR, North Dakota legislature and North Dakota Governor Doug Burgum.

Priority areas for the next month are one-on-one meetings with the P3 proposers; continued work to refine the P3 RFP documents; continued Phase 1 land acquisitions and opportunistic land acquisitions; and participation in the Red River Basin Commission conference.

Ty Smith from CH2M provided an update on in-town levee work and the Oxbow home demolition and relocation project.

7. CORPS OF ENGINEERS UPDATE

Terry Williams, Project Manager from the Corps of Engineers, was present. She provided an update of activities by Corps of Engineers staff which includes issuance of a notice to proceed on the inlet control structure; preparation of preliminary engineering reports for the Wild Rice control structure and southern embankment design; assistance with further development of the P3 RFP; preparation to conduct rights-of-entry and surveys beginning in the spring of 2017; and letter sent to MN DNR Commissioner Tom Landwehr from Colonel Samuel Calkins to reinforce the Corps' position regarding the project.

8. ADMINISTRATIVE/LEGAL UPDATEAdopt Meeting Schedule for 2017

Pursuant to Section 5.11, subsection (b) of the Joint Powers Agreement, at the first meeting in January the board needs to adopt a meeting schedule for the upcoming year.

MOTION, passed

Mr. Piepkorn moved and Mr. Olson seconded to adopt the meeting schedule for the Metro Flood Diversion Authority for 2017. Motion carried.

CH2M Master Services Agreement and Task Order

Mr. Shockley discussed the Master Services Agreement (MSA) and Task Order No. 1 with CH2M, which were approved by the Finance Committee. He said the most significant difference is a change from a lump sum monthly payment to an hourly rate. The MSA is for a three-year term.

MOTION, passed

Mr. Grindberg moved and Mr. Weyland seconded to approve the Master Services Agreement with CH2M. On roll call vote, the motion carried unanimously.

Mr. Shockley said Task Order No. 1 is part of the MSA and is for program management and related services for the period of January 14, 2017, to April 1, 2018.

MOTION, passed

Mr. Grindberg moved and Mr. Hendrickson seconded to approve Task Order 1 with CH2M. On roll call vote, the motion carried unanimously.

Executive Director position description

Mr. Shockley discussed the draft job description for the Executive Director position along with a proposed notice and timeline for the job search. He asked the board to provide any comments or changes to him over the next two weeks. He said compensation for the position has not been determined.

Mr. Vanyo said there has been discussion about hiring a salary consultant similar to the process used by Fargo and Cass County to determine the salary classification. He also said the timeline includes publication of the job notice for up to four months, but this is flexible dependent on the applications that are received.

The consensus of the board was to set a goal to hire the position by this summer. Mr. Shockley will plan to bring this item back to the board for approval at the next meeting.

9. PUBLIC OUTREACH UPDATECommittee report

The Public Outreach Committee met on January 11th. Rocky Schneider from AE2S provided a handout which includes information on the e-newsletter activity and website traffic. He said the newsletter has 1,238 subscribers. Staff also uploaded videos to YouTube which have generated public interest.

10. LAND MANAGEMENT

The Land Management Committee met on January 11th. Mrs. Scherling said the committee discussed the 2017 meeting date schedule, the purposes and goals of the committee, and environmental review and access to properties for survey work. She said the actual land acquisitions are handled by the Cass County Joint Water Resource District (CCJWRD).

11. FINANCE UPDATE

Committee report

The Finance Committee met on January 11th.

Recommended Contracting Actions

Utility Relocation

Robert Cowen from CH2M discussed the following utility relocation, which was reviewed and approved by the Finance Committee:

- City of Fargo (Utility Relocation)—final payment to relocate fiber communication cable from underneath the 2nd Street North flood wall in the amount of \$37,526.38.

MOTION, passed

Mr. Grindberg moved and Mr. Weyland seconded to approve the appropriation of funds for the outlined Utility Relocation. On roll call vote, the motion carried unanimously.

Voucher approval

The bills for the month are with Springsted, Inc. for financial feasibility analysis services; Ohnstad Twichell, P.C. for P3 bond counsel work and 4th Street pump station litigation; and Cass County Joint Water Resource District (CCJWRD) for costs associated with the Metro Flood Diversion, in-town levees, Diversion Project Assessment District, OHB levee, and Oxbow Country Club golf course construction.

Mr. Grindberg said the Finance Committee pulled a \$16,500 line item from the CCJWRD invoice for City of Oxbow auditor services until some questions are answered regarding the cost.

MOTION, passed

Mr. Grindberg moved and Mr. Hendrickson seconded to approve the vouchers received through January 4, 2017, in the amount of \$3,092,473.92, which does not include the Oxbow auditor services line item. On roll call vote, the motion carried unanimously.

12. OTHER BUSINESS

Mr. Mahoney said a meeting was held earlier this week with the North Dakota State Appropriations Committee regarding project funding. He said the payout of \$66.5 million in funds will be done over a four biennium period.

Ms. Williams said names for the MN DNR working group have been submitted.

13. NEXT MEETING DATE

The next meeting will be held on Thursday, January 26, 2017.

14. ADJOURNMENT

MOTION, passed

On motion by Mr. Vanyo, seconded by Mrs. Scherling, and all voting in favor, the meeting was adjourned at 4:20 PM.



JOB DESCRIPTION

JOB TITLE: Executive Director

APPROVED BY: Diversion Authority Board on **January** __, 2017

GENERAL DESCRIPTION

The Executive Director is the chief executive officer of the Metro Flood Diversion Authority (MFDA), reporting directly and responsible to the Diversion Authority (DA) Board for the efficient and effective day-to-day administration and leadership of the FM Metro Area Flood Control Diversion Project (Project).

The MFDA is a political subdivision of the State of North Dakota, and it is a joint-powers entity.¹ The MFDA consists of the following Member Entities: the City of Fargo (ND), the City of Moorhead (MN), Cass County (ND), Clay County (MN), and Cass County Joint Water Resource District (ND). The DA Board is the governing body of the MFDA; its members are appointed from the Member Entities' governing bodies, and the DA Board also includes one (1) member from the West Fargo City Commission.

JOB DUTIES

The Executive Director performs and is responsible for a wide range of duties and tasks as described in the MFDA Joint Powers Agreement. Those and others include, but are not limited to, the following:

1. Responsible for the overall management of all affairs and functions under the jurisdiction of the Diversion Authority Board.
2. Ensure compliance and enforcement of the MFDA Joint Powers Agreement and resolutions of the DA Board.
3. Hire qualified staff to assist the Executive Director in the performance of duties as approved by the DA Board.
4. Responsible for the supervision of all MFDA administration and related functions as directed by the DA Board, including:
 - a. Personnel systems
 - b. Budget systems
 - c. Purchasing systems
 - d. Management Information systems
 - e. Communications systems
 - f. Planning

¹ The MFDA was created by the Joint Powers Agreement, which sets forth the duties and responsibilities of the Executive Director. See Article XIV of the Joint Powers Agreement, available at fmdiversion.com.

5. Responsible for all MFDA purchases including procurement of services as directed by the DA Board and pursuant to purchasing regulations established by the DA Board. Administer various agreements and contracts entered into by the DA Board.
6. Attend DA Board meetings, recommend to the DA Board for adoption measures necessary for the efficient administration of the MFDA's affairs, and keep the DA Board fully informed of the Project.
7. Identify expertise and innovative solutions necessary to administer project tasks, lead a diverse team of consultants, contractors, entity staff, and implement the project.
8. In cooperation with the MFDA Finance Committee, prepare and submit to the DA Board a proposed annual budget and long-range capital expenditure program for such period as the DA Board may direct, each of which shall include detailed estimates of revenue and expenditures, and enforce the provisions of the budget when adopted by the DA Board.
9. Examine the books and papers of officers and departments of the MFDA as directed by the DA Board and report the findings to the DA Board, keep the DA Board fully advised as to the financial condition and needs of the MFDA, and make such other reports from time to time as required by the DA Board or the Executive Director deems advisable.
10. Develop and implement administrative procedures for the MFDA as directed by the DA Board.
11. Represent the MFDA in public and stakeholder meetings and events; serve as the MFDA's ambassador.
12. Responsible for organizing and directing all aspects of government relations; advocate for the project with local, state, and federal staff and elected officials; serve as the MFDA's legislative liaison with local, state, and federal officials.
13. Serve as public information officer for the MFDA.
14. Perform such other management and administrative duties as directed from time to time by the DA Board.
15. Manage and direct the Program Management Consultant.

QUALIFICATIONS AND EXPERIENCE

1. Skills and experience in the development and implementation of public infrastructure projects (preferably over \$500M in total costs) in a management or administrative position.
2. Experience with alternative forms of project delivery, including Design, Build, Finance, Operate, and Maintain (DBFOM) and P3 delivery models.

3. Experience with public speaking, presentations, and media relations.
4. Experience with multi-jurisdictional stakeholder briefings and involvement.
5. Demonstrated ability to maintain focus on critical project issues and make effective decisions to move the project forward.
6. Experience implementing projects under the policy direction of a Board of Directors or elected officials using a mixed team of consultants and entity staff.
7. Experience with governance development.
8. 15+ years of experience required at equal or prerequisite level for the responsibilities and duties of the position.
9. Experience in giving public presentations to local, state, and federal elected and appointed officials.
10. Experience in advising large public boards, commissions, or city councils.
11. Minimum BS/BA or equivalent degree required.
12. PMP Certificate/PE preferred, but not required.

GENERAL SKILLS AND ABILITIES

1. Ability to communicate effectively.
2. Effective interpersonal skills.
3. Data analysis, project design, and project management skills.
4. Labor negotiation and contract administration skills.
5. Ability to provide leadership and motivate others.
6. Ability to prepare and present reports and informational material effectively.

SKILLS AND PERSONAL ATTRIBUTES – SPECIFIC TO MFDA

1. Knowledge of local JPA member agencies, staff, and business practices.
2. Understanding of the Project; its history, status, and long-term importance to the community.
3. Ability to collaborate, build credibility, and establish trust with the Project team, entity staff, the DA Board, and the USACE; foster an effective and collaborative team.

4. Ability to operate as the leader of a team of consultants, entity staff, and local stakeholders.
5. Capable of launching the JPA, and building processes and procedures to implement the Project consistent with the MFDA JPA.
6. Capable and experienced in crisis management, with the ability to proactively manage critical situations.
7. Willingness and ability to commit full-time to the Project for a minimum of 3 to 5 years.
8. Knowledge of USACE policies and procedures within the context of a locally-led and implemented P3.
9. Ability to delegate and leverage team members for effective and efficient Project delivery.
10. Excellent oral, written, and presentation communication skills.
11. Ability to effectively communicate at all levels: senior elected local, state, and federal officials, staff, public, and members of groups affected by the project.

PHYSICAL REQUIREMENTS

- Sedentary to light work.

WORKING RELATIONSHIPS

- Ongoing working relationships with the Member Entities of the MFDA, the Diversion Authority Board and Committee Members, Member Entities' staff, MFDA consultants, USACE, and local, state, and federal officials.

POSITION REPORTS TO

- Diversion Authority Board

BUDGET

- Total MFDA Annual Budget for 2017: _____.



26 January 2017

Finance Committee Report

Presented By:

Program Management Consultant

Report – January 2017

- ▶ Overall Program Status
- ▶ FY 2016 Year End
- ▶ FY 2017 Cash Budget



Overall Program Status



**FM Area Diversion Project
OVERALL PROGRAM (2015\$) SUMMARY**

Schedule Budget Categories	Program Budget (2015\$)	Actuals thru 31 Dec 2016	Remaining Program Budget
PROGRAM	2,205,566,043	332,400,887	1,873,165,156
Diversion Channel & Assoc. Infrastructure	763,768,516	3,320,123	760,448,393
Southern Embankment & Assoc. Infrastructure	371,353,664	51,929,000	319,424,664
Other Mitigation Projects	64,712,848	6,817,389	57,895,459
In-Town Flood Protection	204,863,752	71,880,517	132,983,234
Enabling Work / Other	14,113,749	-	14,113,749
Land Acquisition & Mitigation	426,589,476	134,519,636	292,069,841
Engineering & Design Fees	80,539,955	31,602,663	48,937,292
Program Management	119,725,500	32,331,559	87,393,941
Contingency	159,898,584	-	159,898,584
Debt Service			
Maintenance			

FY 2016 Year End

- ▶ Land Acquisition
 - ▶ Wild Rice Control Structure
 - ▶ Oxbow-Hickson-Bakke (OHB)
 - ▶ Diversion Channel
 - ▶ Upstream Staging Area
- ▶ Construction
 - ▶ OHB – Pump Station, Gatewell, Road Raise, Levee
 - ▶ CR 16/17 Bridge
- ▶ Design / Permitting
 - ▶ Work in Kind / MN DNR
- ▶ Proj Mgmt/Legal/Financing
 - ▶ Re-allocation for local share payment to USACE
- ▶ Mitigation
- ▶ Utility Relocates
 - ▶ Channel / OHB / In Town
- ▶ Retention



2016 Diversion Authority Cash Budget

Annual Budget	Current FY16 Budget	Paid thru 31 Dec 2016 FY16	Expected Additional Payments FY 2016	Remaining FY16 Budget
PROGRAM	237,500,000	161,199,358		76,300,642
Land Acquisition	81,211,609	46,766,050		34,445,559
Construction	69,507,794	48,668,631		20,839,163
Design/Permitting	7,910,478	4,608,023.39		3,302,455
Proj Mgmt/Legal/Financing	60,179,000	61,156,653.15		(977,653)
Mitigation	800,000	-		800,000
Utility Relocates	16,491,119	-		16,491,119
Retention	1,400,000	-		1,400,000

FY 2017 Cash Budget



**FM Area Diversion Project
FY2017 CASH BUDGET**

Schedule Budget Categories	FY2017 Cash Budget	Paid Thru {date}	Expected Additional Payments FY2017	Remaining FY 2017 Budget
PROGRAM	241,311,231		241,311,231	241,311,231
Diversion Channel & Assoc. Infrastructure	16,575,999		16,575,999	16,575,999
Southern Embankment & Assoc. Infrastructure	100,000		100,000	100,000
Other Mitigation Projects	24,246,248		24,246,248	24,246,248
In-Town Flood Protection	46,175,722		46,175,722	46,175,722
Enabling Work / Other	9,810,803		9,810,803	9,810,803
Land Acquisition & Mitigation	107,419,540		107,419,540	107,419,540
Engineering & Design Fees	10,693,575		10,693,575	10,693,575
Program Management	17,247,196		17,247,196	17,247,196
Contingency	804,879		804,879	804,879
Debt Service	8,137,268		8,137,268	8,137,268
Maintenance	100,000		100,000	100,000

Finance Committee Bills through January 18, 2017

Vendor	Description		
Erik R. Johnson & Associates, Ltd.	Legal services rendered through December 31, 2016	\$	1,453.04
Total Bills Received through January 18, 2017		\$	1,453.04

Erik R. Johnson & Associates, Ltd.
Attorneys at Law

City of Fargo-Auditor's Office
Attn: Kent Costin
200 North Third Street
Fargo, ND 58102

Invoice No. 2504

RE: Metro Flood Project-General Legal Matters

For Legal Services Rendered Through December 31, 2016

INVOICE TOTAL

Total for Current Legal Fees	\$1362.80
Total for Current Disbursements and Service Charges	\$90.24
Total for Current Invoice	\$1453.04

Summary of Account

*Prior Balance Due	\$
Total Amount Due	\$1453.04

*If payment has been submitted for prior balance due, please disregard.

We appreciate your business.

790-7910-429.33- 25 000102

505 Broadway Street North • Suite 206 • Fargo, ND 58102
Phone: (701) 280-1901 • • • Fax: (701) 280-1902

Recommended Contracting Actions Summary

Construction Change Orders

Pending Approval of Finance Committee

<i>Construction Change Orders</i>		
WP-42A.1/A.3, 4th Street Pump Station Change Order 09 <ul style="list-style-type: none">Fuel level Sensors, Floodwall coping, and Trash Rack Modifications	ICS, Inc.	\$12,506.80
Total Construction Change Orders		\$12,506.80



Technical Advisory Group Recommendation

Meeting Date: 01/17/2017

RECOMMENDATION FOR ACTION:

The Technical Advisory Group has reviewed and recommends approval of the following Contract Action(s).

SUMMARY OF CONTRACTING ACTION:

Per the contract review and approval procedures, Section 5.C(2), that were adopted by the Diversion Authority on November 10, 2016, the Owner’s Program Management Consultant (PMC) or Engineer of Record (EOR) shall submit a construction Change Order request to the Technical Advisory Group. The Technical Advisory Group shall review the Change Order request during its next regular meeting after receiving the Change Order request, and make a recommendation as to approval or denial of the Change Order request.

The Owner’s Representative has reviewed and recommends the following Contract Action(s):

Description	Budget Estimate (\$)
ICS, Inc. <i>Change Order #09</i>	<i>\$12,506.80</i>
WP-42A.1/A.3, 4 th Street Pump Station and Floodwall – Fuel level Sensors, Floodwall Coping, and Trash Rack Modifications.	

Summary of Contracting History and Current Contract Action:

Original Agreement or Amendment	Budget (\$) Change	Previous Project Cost	Revised Project Cost	Project Start	Project Completion	Comments
WP-42A.1/A.3 contract	17,361,616.35	0.00	17,361,616.35	11-Dec-14	11-Nov-16	Awarded 4 th Street Pump Station and 2 nd Street South Floodwall
Change Order 1	268,555.24	17,361,616.35	17,630,171.59	11-Dec-14	11-Nov-16	Fargo Highrise parking lot modifications and other costs
Change Order 2	176,462.97	17,630,171.59	17,806,634.56	11-Dec-14	11-Nov-16	Unknown underground structures and other costs
Change Order 3	(10,570.93)	17,806,634.56	17,796,063.63	11-Dec-14	11-Nov-16	Deduct exterior electrical work and install fence, bollards, and lights at Fargo Highrise
Change Order 4	15,174.67	17,796,063.63	17,811,238.30	11-Dec-14	11-Nov-16	Time extensions and multiple cost adjustments for Engineer- and Owner-directed items.
Change Order 5	70,363.71	17,811,238.30	17,881,601.31	11-Dec-14	11-Nov-16	Last of suspended changes, sanitary overflow connection, T&M budget for ACM removal

Change Order 6	147,079.47	17,881,601.31	18,028,681.48	11-Dec-14	11-Nov-16	Last of suspended changes, erosion blanket, still wells, unsuitable materials and additional asbestos wrapped pipe.
Change Order 7	11,147.81	18,028,681.48	18,036,371.39	11-Dec-14	13-Sept-17	Sanitary Overflow Brackets, ST-4 Flared End with Grate, Sluice Gate Actuator Covers and 2" nuts, Updated Lot Grading Plan, Milestone and Project Completion Date Resets, and Time Additions.
Change Order 8	2,386.00	18,036,371.39	18,038,757.39	11-Dec-14	13-Sept-17	Reprogramming Display and Generator Building Fuel Storage Area Drain
Change Order 9	12,506.80	18,038,757.39	18,051,264.19	11-Dec-14	13-Sept-17	Fuel Sensors, Floodwall Coping, and Trash Rack Modifications

DISCUSSION

Change Order No. 9 increases the Contract Price by a total of **\$12,506.80** as listed below:

- Fuel Level Sensors.** The generator fuel tank’s fuel level sensing system is specified to alarm at three (3) levels: low level alarm at 15% capacity, a high level alarm at 95%, and a high-high level alarm at 98% capacity. This Owner requested change will add three level sensing points: 25%, 50%, and 75% capacity, to allow better monitoring of fuel levels. Four systems were proposed by Fusion, the Contractor’s electrical Subcontractor and the Owner selected Option A as the preferred option. The 2nd Street pump station was outfitted with a similar sensing system that monitors these additional fuel tank levels. This change adds \$1,906.80 to the Contract Price. The Owner’s Representative and Engineer have reviewed this cost and found it to be reasonable.
- Floodwall Coping.** At the Owner’s request, higher pitched floodwall coping is being incorporated on the in-town floodwalls to discourage personal access to the top of the wall once complete. This change is consistent with changes made on 42F.1S and 42F.1N. This adds \$4,205.00 to the Contract Price for the Contractor to furnish and install higher pitched wall caps than were originally specified. The Owner’s Representative and Engineer have reviewed this cost and found it to be reasonable.
- Trash Rack Modifications.** The installed trash racks do not operate smoothly and jam frequently during operation. The Engineer, with assistance from the Contractor, has researched and developed a solution that includes fabricating and installing additional guide rollers on each of the trash racks. This change adds \$6,393.00 to the Contract Price to fabricate, install, and test the guide rollers. The Owner’s Representative and Engineer have reviewed this cost and found it to be reasonable.

ATTACHMENT(S):

- Draft Change Order No. 9
- Fuel Level Sensor Cost Letter from ICS dated 1/3/2017
- Floodwall Coping Cost Letter from ICS dated 1/3/2017
- Trash Rack Modifications Cost Letter from ICS dated 1/5/2017

Submitted by:



Tyler Smith, P.E.
CH2M
Project Manager
Metro Flood Diversion Project

January 16, 2017

Date

Mark Bittner, Fargo Director of Engineering

Concur: January 17, 2017 Non-Concur: _____

April Walker, Fargo City Engineer

Concur: January 17, 2017 Non-Concur _____

David Overbo, Clay County Engineer

Concur: _____ Non-Concur: _____

Jason Benson, Cass County Engineer

Concur: January 17, 2017 Non-Concur _____

Nathan Boerboom, Diversion Authority Project
Manager

Concur: January 17, 2017 Non-Concur: _____

Robert Zimmerman, Moorhead City Engineer

Concur: January 17, 2017 Non-Concur _____



Change Order No. 09

Date of Issuance:	<u>01/26/2017</u>	Effective Date:	<u>12/01/2016</u>
Owner:	<u>Metro Flood Diversion Authority</u>	Owner's Contract No.:	<u>WP-42A.1/A.3</u>
Owner's Representative:	<u>CH2M HILL Engineers, Inc.</u>	Owner's Representative Project No.:	<u>435534</u>
Contractor:	<u>ICS, Inc.</u>	Contractor's Project No.:	<u>1114</u>
Engineer:	<u>Houston-Moore Group, LLC</u>	Work Package No.:	<u>WP-42A.1/A.3</u>
Project:	<u>Fargo-Moorhead Area Diversion</u>	Contract Name:	<u>4th Street Pump Station and Gatewell and 2nd Street Floodwall South</u>

The Contract is modified as follows upon execution of this Change Order:

Description:

1. FUEL LEVEL SENSORS
Add \$1,906.80 to the Contract Price to accommodate additional fuel level sensors that will monitor the 25%, 50%, and 75% fuel levels in the generator fuel tank.
2. FLOODWALL COPING
Add \$4205.00 to the Contract Price for the contractor to furnish and install higher pitched wall coping for the floodwall south of 2nd Street.
3. TRASH RACK MODIFICATIONS
Add \$6,393.00 to the Contract Price to accommodate the installation of modifications to the trash racks.

Attachments:

- Change Order 9 Unit Price Schedule dated 1/11/2017

CHANGE IN CONTRACT PRICE	CHANGE IN CONTRACT TIMES
Original Contract Price:	Original Contract Times:
	Milestone 4.02.A.02: <u>November 1, 2015</u>
	Milestone 4.02.A.02a: <u>NA</u>
	Milestone 4.02.A.03: <u>July 31, 2015</u>
	Milestone 4.02.A.04: <u>August 20, 2015</u>
	Milestone 4.02.A.05: <u>November 13, 2015</u>
	Milestone 4.02.A.06: <u>January 26, 2016</u>
	Milestone 4.02.A.07: <u>September 5, 2016</u>
	Substantial Completion 4.02 B: <u>September 5, 2016</u>
17,361,616.35	Final Completion 4.02 B: <u>November 11, 2016</u>

<p>[Increase] [Decrease] from previously approved Change Orders No. <u>01</u> thru <u>07</u>:</p> <p style="text-align: right;">677,141.04</p>	<p>[Increase] [Decrease] from previously approved Change Orders No. <u>01</u> thru <u>06</u>:</p> <p>Milestone 4.02.A.02: <u>30 days</u> Milestone 4.02.A.02.a: <u>14 days</u> Milestone 4.02.A.03: <u>29 days</u> Milestone 4.02.A.04: <u>29 days</u> Milestone 4.02.A.05: <u>30 days</u> Milestone 4.02.A.06: <u>309 days</u> Milestone 4.02.A.07: <u>309 days</u> Substantial Completion 4.02 B: <u>309 days</u> Final Completion 4.02 B: <u>306 days</u></p>
--	---

<p>Contract Price prior to this Change Order:</p> <p style="text-align: right;">18,038,757.39</p>	<p>Contract Times prior to this Change Order:</p> <p>Milestone 4.02.A.02: <u>December 1, 2015</u> Milestone 4.02.A.02a: <u>November 15, 2015</u> Milestone 4.02.A.03: <u>August 29, 2015</u> Milestone 4.02.A.04: <u>September 18, 2015</u> Milestone 4.02.A.05: <u>December 13, 2015</u> Milestone 4.02.A.06: <u>December 3, 2016</u> Milestone 4.02.A.07: <u>July 11, 2017</u> Substantial Completion 4.02 B: <u>July 11, 2017</u> Final Completion 4.02 B: <u>September 13, 2017</u></p>
--	---

<p>[Increase] [Decrease] of this Change Order:</p> <p style="text-align: right;">12,506.80</p>	<p>[Increase] [Decrease] of this Change Order:</p> <p>Milestone 4.02.A.07: <u>2 days</u> Substantial Completion 4.02 B: <u>2 days</u></p>
--	---

<p>Contract Price incorporating this Change Order:</p> <p style="text-align: right;">18,051,264.19</p>	<p>Contract Times with all approved Change Orders:</p> <p>Milestone 4.02.A.02: <u>December 1, 2015</u> Milestone 4.02.A.02a: <u>November 15, 2015</u> Milestone 4.02.A.03: <u>August 29, 2015</u> Milestone 4.02.A.04: <u>September 18, 2015</u> Milestone 4.02.A.05: <u>December 13, 2015</u> Milestone 4.02.A.06: <u>December 3, 2016</u> Milestone 4.02.A.07: <u>July 13, 2017</u> Substantial Completion 4.02 B: <u>July 13, 2017</u> Final Completion 4.02 B: <u>September 13, 2017</u></p>
---	--

<p>RECOMMENDED:</p> <p>By: _____ Owner's Representative (Authorized Signature)</p> <p>Title: <u>Construction Manager</u></p> <p>Date: <u>01/26/2017</u></p>	<p>ACCEPTED:</p> <p>By: _____ Owner (Authorized Signature)</p> <p>Title: _____</p> <p>Date: _____</p>	<p>ACCEPTED:</p> <p>By: _____ Contractor (Authorized Signature)</p> <p>Title: _____</p> <p>Date: _____</p>
--	--	---

WP-42A.1/A.3

4th Street Pump Station and Gatewell - 2nd Street Floodwall South

Change Order 9 Unit Price Schedule
DATE: 1/11/2016



WP-42A.1/A.3 - 4th Street Pump Station and Gatewell - 2nd Street Floodwall South											
ITEM	DESCRIPTION	UNIT	Current Budget (thru CO-06)			Net Change			New Budget		
			QUANTITY	UNIT PRICE	AMOUNT	QUANTITY	UNIT PRICE	AMOUNT	QUANTITY	UNIT PRICE	AMOUNT
0001	Mobilization	LS	1	\$ 350,000.00	\$ 350,000.00	0	\$ -	\$ -	1	\$ 350,000.00	\$ 350,000.00
0002	Remove Sanitary Sewer Manhole	EA	2	\$ 1,100.00	\$ 2,200.00	0	\$ -	\$ -	2	\$ 1,100.00	\$ 2,200.00
0003	F&I Pipe SDR 26 - 10" Dia PVC	LF	145	\$ 70.00	\$ 10,150.00	0	\$ -	\$ -	145	\$ 70.00	\$ 10,150.00
0004	Remove Sanitary Sewer Pipe All Sizes All Types	LF	140	\$ 11.00	\$ 1,540.00	0	\$ -	\$ -	140	\$ 11.00	\$ 1,540.00
0005	Rem & Repl Sanitary Sewer Casting - Floating Manhole	EA	1	\$ 800.00	\$ 800.00	0	\$ -	\$ -	1	\$ 800.00	\$ 800.00
0006	Sanitary Sewer Manhole	EA	2	\$ 4,500.00	\$ 9,000.00	0	\$ -	\$ -	2	\$ 4,500.00	\$ 9,000.00
0007	Sanitary Sewer Exterior Drop Manhole	EA	1	\$ 12,000.00	\$ 12,000.00	0	\$ -	\$ -	1	\$ 12,000.00	\$ 12,000.00
0008	F&I 5" Hydrant	EA	2	\$ 6,000.00	\$ 12,000.00	0	\$ -	\$ -	2	\$ 6,000.00	\$ 12,000.00
0009	Salvage Hydrant	EA	2	\$ 600.00	\$ 1,200.00	0	\$ -	\$ -	2	\$ 600.00	\$ 1,200.00
0010	F&I Pipe C900 DR 18 - 6" Dia PVC	LF	479	\$ 60.00	\$ 28,740.00	0	\$ -	\$ -	479	\$ 60.00	\$ 28,740.00
0011	F&I Pipe C900 DR 18 - 10" Dia PVC	LF	416	\$ 65.00	\$ 27,040.00	0	\$ -	\$ -	416	\$ 65.00	\$ 27,040.00
0012	Remove Water Main Pipe All Sizes All Types	LF	697	\$ 11.00	\$ 7,667.00	0	\$ -	\$ -	697	\$ 11.00	\$ 7,667.00
0013	F&I Gate Valve 6" Dia	EA	5	\$ 2,200.00	\$ 11,000.00	0	\$ -	\$ -	5	\$ 2,200.00	\$ 11,000.00
0014	F&I Gate Valve 10" Dia	EA	3	\$ 4,000.00	\$ 12,000.00	0	\$ -	\$ -	3	\$ 4,000.00	\$ 12,000.00
0015	Watermain Fittings	LBS	4,157	\$ 12.00	\$ 49,884.00	0	\$ -	\$ -	4,157	\$ 12.00	\$ 49,884.00
0016	F&I Overflow Structure	EA	1	\$ 18,000.00	\$ 18,000.00	0	\$ -	\$ -	1	\$ 18,000.00	\$ 18,000.00
0017	F&I Manhole 4' Dia Reinf Conc	EA	3	\$ 5,000.00	\$ 15,000.00	0	\$ -	\$ -	3	\$ 5,000.00	\$ 15,000.00
0018	F&I Manhole 5' Dia Reinf Conc	EA	1	\$ 5,000.00	\$ 5,000.00	0	\$ -	\$ -	1	\$ 5,000.00	\$ 5,000.00
0019	F&I Manhole 6' Dia Reinf Conc	EA	2	\$ 20,000.00	\$ 40,000.00	0	\$ -	\$ -	2	\$ 20,000.00	\$ 40,000.00
0020	F&I Manhole 7' Dia Reinf Conc	EA	3	\$ 22,000.00	\$ 66,000.00	0	\$ -	\$ -	3	\$ 22,000.00	\$ 66,000.00
0021	F&I Manhole Type E Reinf Conc	EA	2	\$ 70,000.00	\$ 140,000.00	0	\$ -	\$ -	2	\$ 70,000.00	\$ 140,000.00
0022	F&I Manhole Type E Reinf Conc (ST-4)	EA	1	\$ 250,000.00	\$ 250,000.00	0	\$ -	\$ -	1	\$ 250,000.00	\$ 250,000.00
0023	F&I Manhole Type E Reinf Conc (ST-3)	EA	1	\$ 225,000.00	\$ 225,000.00	0	\$ -	\$ -	1	\$ 225,000.00	\$ 225,000.00
0024	F&I Manhole Type E Reinf Conc (ST-2)	EA	1	\$ 225,000.00	\$ 225,000.00	0	\$ -	\$ -	1	\$ 225,000.00	\$ 225,000.00
0025	F&I Manhole Type E Reinf Conc (ST-1)	EA	1	\$ 225,000.00	\$ 225,000.00	0	\$ -	\$ -	1	\$ 225,000.00	\$ 225,000.00
0026	Remove Storm Sewer Manhole	EA	5	\$ 600.00	\$ 3,000.00	0	\$ -	\$ -	5	\$ 600.00	\$ 3,000.00
0027	F&I Inlet - Manhole (MHI) 4' Dia Reinf Conc	EA	1	\$ 5,000.00	\$ 5,000.00	0	\$ -	\$ -	1	\$ 5,000.00	\$ 5,000.00
0028	F&I Inlet - Manhole (MHI) 6' Dia Reinf Conc	EA	1	\$ 15,000.00	\$ 15,000.00	0	\$ -	\$ -	1	\$ 15,000.00	\$ 15,000.00
0029	F&I Inlet - Single Box (SBI) Reinf Conc	EA	1	\$ 5,000.00	\$ 5,000.00	0	\$ -	\$ -	1	\$ 5,000.00	\$ 5,000.00

WP-42A.1/A.3

4th Street Pump Station and Gatewell - 2nd Street Floodwall South

Change Order 9 Unit Price Schedule
DATE: 1/11/2016



WP-42A.1/A.3 - 4th Street Pump Station and Gatewell - 2nd Street Floodwall South											
ITEM	DESCRIPTION	UNIT	Current Budget (thru CO-06)			Net Change			New Budget		
			QUANTITY	UNIT PRICE	AMOUNT	QUANTITY	UNIT PRICE	AMOUNT	QUANTITY	UNIT PRICE	AMOUNT
0030	F&I Inlet - Double Box (DBI) Reinf Conc	EA	1	\$ 7,000.00	\$ 7,000.00	0	\$ -	\$ -	1	\$ 7,000.00	\$ 7,000.00
0031	F&I Inlet - Special (SPI) Reinf Conc	EA	2	\$ 2,000.00	\$ 4,000.00	0	\$ -	\$ -	2	\$ 2,000.00	\$ 4,000.00
0032	Riprap (Outlet)	CY	410	\$ 125.00	\$ 51,250.00	0	\$ -	\$ -	410	\$ 125.00	\$ 51,250.00
0033	Box Culvert End Section with Gate	EA	1	\$ 25,000.00	\$ 25,000.00	0	\$ -	\$ -	1	\$ 25,000.00	\$ 25,000.00
0034	PLUG PIPE 33" DIA.	EA	1	\$ 1,500.00	\$ 1,500.00	0	\$ -	\$ -	1	\$ 1,500.00	\$ 1,500.00
0035	PLUG PIPE 72" DIA.	EA	1	\$ 3,300.00	\$ 3,300.00	0	\$ -	\$ -	1	\$ 3,300.00	\$ 3,300.00
0036	PLUG PIPE 78" DIA.	EA	2	\$ 4,500.00	\$ 9,000.00	0	\$ -	\$ -	2	\$ 4,500.00	\$ 9,000.00
0037	F&I Pipe 18" Dia Reinf Conc	LF	291	\$ 95.00	\$ 27,645.00	0	\$ -	\$ -	291	\$ 95.00	\$ 27,645.00
0038	F&I Pipe 24" Dia Reinf Conc	LF	86	\$ 120.00	\$ 10,320.00	0	\$ -	\$ -	86	\$ 120.00	\$ 10,320.00
0039	F&I Pipe 30" Dia Reinf Conc	LF	137	\$ 220.00	\$ 30,140.00	0	\$ -	\$ -	137	\$ 220.00	\$ 30,140.00
0040	F&I Pipe 36" Dia Reinf Conc	LF	8	\$ 250.00	\$ 2,000.00	0	\$ -	\$ -	8	\$ 250.00	\$ 2,000.00
0041	F&I Pipe 48" Dia Reinf Conc	LF	79	\$ 300.00	\$ 23,700.00	0	\$ -	\$ -	79	\$ 300.00	\$ 23,700.00
0042	F&I Pipe 54" Dia Reinf Conc	LF	79	\$ 800.00	\$ 63,200.00	0	\$ -	\$ -	79	\$ 800.00	\$ 63,200.00
0043	F&I Pipe 72" Dia Reinf Conc	LF	51	\$ 900.00	\$ 45,900.00	0	\$ -	\$ -	51	\$ 900.00	\$ 45,900.00
0044	F&I Pipe 12" Dia PVC	LF	99	\$ 120.00	\$ 11,880.00	0	\$ -	\$ -	99	\$ 120.00	\$ 11,880.00
0045	Remove Storm Sewer Pipe All Sizes All Types	LF	2,788	\$ 85.00	\$ 236,980.00	0	\$ -	\$ -	2,788	\$ 85.00	\$ 236,980.00
0046	30" Flapgate	EA	-	\$ 25,000.00	\$ -	0	\$ -	\$ -	-	\$ 25,000.00	\$ -
0047	54" Flapgate	EA	1	\$ 30,000.00	\$ 30,000.00	0	\$ -	\$ -	1	\$ 30,000.00	\$ 30,000.00
0048	F&I Pipe w/GB 30" Dia Reinf Conc	LF	240	\$ 1,100.00	\$ 264,000.00	0	\$ -	\$ -	240	\$ 1,100.00	\$ 264,000.00
0049	F&I Pipe w/GB 36" Dia Reinf Conc	LF	88	\$ 1,200.00	\$ 105,600.00	0	\$ -	\$ -	88	\$ 1,200.00	\$ 105,600.00
0050	F&I Pipe w/GB 54" Dia Reinf Conc	LF	19	\$ 2,000.00	\$ 38,000.00	0	\$ -	\$ -	19	\$ 2,000.00	\$ 38,000.00
0051	F&I Box Culvert 8'x5' Wide Reinf Conc Cast in Place with depth of fill 1' to 10'	LF	495	\$ 1,500.00	\$ 742,500.00	0	\$ -	\$ -	495	\$ 1,500.00	\$ 742,500.00
0052	F&I Box Culvert 8'x5' Wide Reinf Conc Cast in Place with depth of fill 10' to 31'	LF	128	\$ 2,800.00	\$ 358,400.00	0	\$ -	\$ -	128	\$ 2,800.00	\$ 358,400.00
0053	F&I Box Culvert 8'x5' Wide Reinf Conc Precast	LF	186	\$ 1,300.00	\$ 241,800.00	0	\$ -	\$ -	186	\$ 1,300.00	\$ 241,800.00
0054	Remove Pavement All Thicknesses All Types	SY	8,226	\$ 10.00	\$ 82,260.00	0	\$ -	\$ -	8,226	\$ 10.00	\$ 82,260.00
0055	Subgrade Preparation	SY	10,496	\$ 4.50	\$ 47,232.00	0	\$ -	\$ -	10,496	\$ 4.50	\$ 47,232.00
0056	F&I Woven Geotextile	SY	10,496	\$ 2.50	\$ 26,240.00	0	\$ -	\$ -	10,496	\$ 2.50	\$ 26,240.00
0057	F&I Class 5 Agg - 6" Thick	SY	5,578	\$ 10.00	\$ 55,780.00	0	\$ -	\$ -	5,578	\$ 10.00	\$ 55,780.00
0058	F&I Class 5 Agg - 7" Thick	SY	2,212	\$ 12.00	\$ 26,544.00	0	\$ -	\$ -	2,212	\$ 12.00	\$ 26,544.00

WP-42A.1/A.3

4th Street Pump Station and Gatewell - 2nd Street Floodwall South

Change Order 9 Unit Price Schedule
DATE: 1/11/2016



WP-42A.1/A.3 - 4th Street Pump Station and Gatewell - 2nd Street Floodwall South											
ITEM	DESCRIPTION	UNIT	Current Budget (thru CO-06)			Net Change			New Budget		
			QUANTITY	UNIT PRICE	AMOUNT	QUANTITY	UNIT PRICE	AMOUNT	QUANTITY	UNIT PRICE	AMOUNT
0059	F&I Class 5 Agg - 8" Thick	SY	733	\$ 13.00	\$ 9,529.00	0	\$ -	\$ -	733	\$ 13.00	\$ 9,529.00
0060	F&I Class 5 Agg - 12" Thick	SY	1,973	\$ 20.00	\$ 39,460.00	0	\$ -	\$ -	1,973	\$ 20.00	\$ 39,460.00
0061	F&I Crushed Conc - 6" Thick	SY	120	\$ 13.00	\$ 1,560.00	0	\$ -	\$ -	120	\$ 13.00	\$ 1,560.00
0062	F&I Curb & Gutter Standard (Type II)	LF	2,030	\$ 40.00	\$ 81,200.00	0	\$ -	\$ -	2,030	\$ 40.00	\$ 81,200.00
0063	Remove Curb & Gutter	LF	1,924	\$ 10.00	\$ 19,240.00	0	\$ -	\$ -	1,924	\$ 10.00	\$ 19,240.00
0064	F&I Pavement 6" Thick Reinf Conc	SY	3,744	\$ 66.00	\$ 247,104.00	0	\$ -	\$ -	3,744	\$ 66.00	\$ 247,104.00
0065	F&I Pavement 7" Thick Reinf Conc	SY	1,484	\$ 75.00	\$ 111,300.00	0	\$ -	\$ -	1,484	\$ 75.00	\$ 111,300.00
0066	F&I Pavement 9" Thick Doweled Conc	SY	1,519	\$ 90.00	\$ 136,710.00	0	\$ -	\$ -	1,519	\$ 90.00	\$ 136,710.00
0067	F&I Sidewalk 4" Thick Reinf Conc	SY	1,401	\$ 60.00	\$ 84,060.00	0	\$ -	\$ -	1,401	\$ 60.00	\$ 84,060.00
0068	Remove Sidewalk All Thicknesses All Types	SY	1,112	\$ 15.00	\$ 16,680.00	0	\$ -	\$ -	1,112	\$ 15.00	\$ 16,680.00
0069	Temp Construction Entrance	EA	4	\$ 1,700.00	\$ 6,800.00	0	\$ -	\$ -	4	\$ 1,700.00	\$ 6,800.00
0070	Traffic Control - Type 1	LS	1	\$ 26,000.00	\$ 26,000.00	0	\$ -	\$ -	1	\$ 26,000.00	\$ 26,000.00
0071	F&I Aggregate for Asph Pavement Class 29	TON	930	\$ 80.00	\$ 74,400.00	0	\$ -	\$ -	930	\$ 80.00	\$ 74,400.00
0072	F&I Asphalt Cement PG 58-28	GAL	13,385	\$ 4.00	\$ 53,540.00	0	\$ -	\$ -	13,385	\$ 4.00	\$ 53,540.00
0073	F&I Impressioned 4" Thick Reinf Conc	SY	72	\$ 220.00	\$ 15,840.00	0	\$ -	\$ -	72	\$ 220.00	\$ 15,840.00
0074	F&I Det Warn Panels Cast Iron	SF	109	\$ 70.00	\$ 7,630.00	0	\$ -	\$ -	109	\$ 70.00	\$ 7,630.00
0075	F&I Sign Assembly	EA	18	\$ 220.00	\$ 3,960.00	0	\$ -	\$ -	18	\$ 220.00	\$ 3,960.00
0076	Relocate Sign Assembly	EA	13	\$ 220.00	\$ 2,860.00	0	\$ -	\$ -	13	\$ 220.00	\$ 2,860.00
0077	F&I Engineering Grade	SF	23	\$ 30.00	\$ 690.00	0	\$ -	\$ -	23	\$ 30.00	\$ 690.00
0078	F&I Diamond Grade Cubed	SF	6	\$ 40.00	\$ 252.00	0	\$ -	\$ -	6	\$ 40.00	\$ 252.00
0079	F&I High Intensity Prismatic	SF	28	\$ 35.00	\$ 966.00	0	\$ -	\$ -	28	\$ 35.00	\$ 966.00
0080	F&I Flexible Delineator	EA	2	\$ 130.00	\$ 260.00	0	\$ -	\$ -	2	\$ 130.00	\$ 260.00
0081	F&I Grooved Plastic Film Message	SF	80	\$ 50.00	\$ 4,000.00	0	\$ -	\$ -	80	\$ 50.00	\$ 4,000.00
0082	F&I Grooved Plastic Film 4" Wide	LF	1,485	\$ 10.00	\$ 14,850.00	0	\$ -	\$ -	1,485	\$ 10.00	\$ 14,850.00
0083	F&I Grooved Plastic Film 24" Wide	LF	72	\$ 40.00	\$ 2,880.00	0	\$ -	\$ -	72	\$ 40.00	\$ 2,880.00
0084	Paint Epoxy Message	SF	32	\$ 20.00	\$ 640.00	0	\$ -	\$ -	32	\$ 20.00	\$ 640.00
0085	Paint Epoxy Line 4" Wide	LF	3,244	\$ 6.00	\$ 19,464.00	0	\$ -	\$ -	3,244	\$ 6.00	\$ 19,464.00
0086	Paint Epoxy Line 8" Wide	LF	234	\$ 10.00	\$ 2,340.00	0	\$ -	\$ -	234	\$ 10.00	\$ 2,340.00
0087	Paint Epoxy Line 24" Wide	LF	-	\$ 20.00	\$ -	0	\$ -	\$ -	-	\$ 20.00	\$ -

WP-42A.1/A.3
4th Street Pump Station and Gatewell - 2nd Street Floodwall South

Change Order 9 Unit Price Schedule
 DATE: 1/11/2016



WP-42A.1/A.3 - 4th Street Pump Station and Gatewell - 2nd Street Floodwall South											
ITEM	DESCRIPTION	UNIT	Current Budget (thru CO-06)			Net Change			New Budget		
			QUANTITY	UNIT PRICE	AMOUNT	QUANTITY	UNIT PRICE	AMOUNT	QUANTITY	UNIT PRICE	AMOUNT
0088	Obliterate Pavement Markings	SF	182	\$ 35.00	\$ 6,370.00	0	\$ -	\$ -	182	\$ 35.00	\$ 6,370.00
0089	Temp Fence - Safety	LF	2,167	\$ 6.00	\$ 13,002.00	0	\$ -	\$ -	2,167	\$ 6.00	\$ 13,002.00
0090	Remove Fence	LF	202	\$ 27.00	\$ 5,454.00	0	\$ -	\$ -	202	\$ 27.00	\$ 5,454.00
0091	Temp Pumping	LS	1	\$ 95,000.00	\$ 95,000.00	0	\$ -	\$ -	1	\$ 95,000.00	\$ 95,000.00
0092	Clear & Grub	LS	1	\$ 15,000.00	\$ 15,000.00	0	\$ -	\$ -	1	\$ 15,000.00	\$ 15,000.00
0093	Remove Tree	EA	19	\$ 600.00	\$ 11,400.00	0	\$ -	\$ -	19	\$ 600.00	\$ 11,400.00
0094	Silt Fence - Standard	LF	784	\$ 4.00	\$ 3,136.00	0	\$ -	\$ -	784	\$ 4.00	\$ 3,136.00
0095	Floating Silt Fence	LF	93	\$ 30.00	\$ 2,790.00	0	\$ -	\$ -	93	\$ 30.00	\$ 2,790.00
0096	Sediment Control Log 6" to 8" Dia	LF	1,130	\$ 3.00	\$ 3,390.00	0	\$ -	\$ -	1,130	\$ 3.00	\$ 3,390.00
0097	Inlet Protection - New Inlet	EA	7	\$ 300.00	\$ 2,100.00	0	\$ -	\$ -	7	\$ 300.00	\$ 2,100.00
0098	Inlet Protection - Existing Inlet	EA	9	\$ 200.00	\$ 1,800.00	0	\$ -	\$ -	9	\$ 200.00	\$ 1,800.00
0099	Salvage Signal Standard	EA	1	\$ 300.00	\$ 300.00	0	\$ -	\$ -	1	\$ 300.00	\$ 300.00
0100	Lighting System	LS	1	\$ 20,000.00	\$ 20,000.00	0	\$ -	\$ -	1	\$ 20,000.00	\$ 20,000.00
0101	Propane Tanks Remove and Replace	LS	1	\$ 20,000.00	\$ 20,000.00	0	\$ -	\$ -	1	\$ 20,000.00	\$ 20,000.00
0102	Replace Unsalvagable Bollards	EA	40	\$ 1,000.00	\$ 40,000.00	0	\$ -	\$ -	40	\$ 1,000.00	\$ 40,000.00
0103	Revise Flashing Beacon System	LS	1	\$ 15,000.00	\$ 15,000.00	0	\$ -	\$ -	1	\$ 15,000.00	\$ 15,000.00
0104	Revise Traffic Control System	LS	1	\$ 20,000.00	\$ 20,000.00	0	\$ -	\$ -	1	\$ 20,000.00	\$ 20,000.00
0105	F&I Bus Shelter	EA	1	\$ 30,000.00	\$ 30,000.00	0	\$ -	\$ -	1	\$ 30,000.00	\$ 30,000.00
0106	F&I Sheet Piling - Steel	SF	168	\$ 65.00	\$ 10,920.00	0	\$ -	\$ -	168	\$ 65.00	\$ 10,920.00
0107	Topsoil - Strip	CY	5,870	\$ 5.00	\$ 29,350.00	0	\$ -	\$ -	5,870	\$ 5.00	\$ 29,350.00
0108	Topsoil - Spread	CY	2,784	\$ 5.00	\$ 13,920.00	0	\$ -	\$ -	2,784	\$ 5.00	\$ 13,920.00
0109	Embankment	CY	45,017	\$ 13.00	\$ 585,221.00	0	\$ -	\$ -	45,017	\$ 13.00	\$ 585,221.00
0110	Embankment Import	CY	8,617	\$ 22.00	\$ 189,574.00	0	\$ -	\$ -	8,617	\$ 22.00	\$ 189,574.00
0111	Excavation	CY	36,400	\$ 9.00	\$ 327,600.00	0	\$ -	\$ -	36,400	\$ 9.00	\$ 327,600.00
0112	Grading North of 2nd St S and West of 4th St S	LS	1	\$ 20,000.00	\$ 20,000.00	0	\$ -	\$ -	1	\$ 20,000.00	\$ 20,000.00
0113	Mulching Type 1 - Hydro	SY	16,703	\$ 0.50	\$ 8,351.50	0	\$ -	\$ -	16,703	\$ 0.50	\$ 8,351.50
0114	Seeding Type B	SY	16,703	\$ 0.35	\$ 5,846.05	0	\$ -	\$ -	16,703	\$ 0.35	\$ 5,846.05
0115	Overseeding	SY	33,405	\$ 0.25	\$ 8,351.25	0	\$ -	\$ -	33,405	\$ 0.25	\$ 8,351.25
0116	Weed Control Type B	SY	16,703	\$ 0.15	\$ 2,505.45	0	\$ -	\$ -	16,703	\$ 0.15	\$ 2,505.45

WP-42A.1/A.3

4th Street Pump Station and Gatewell - 2nd Street Floodwall South

Change Order 9 Unit Price Schedule
DATE: 1/11/2016



WP-42A.1/A.3 - 4th Street Pump Station and Gatewell - 2nd Street Floodwall South											
ITEM	DESCRIPTION	UNIT	Current Budget (thru CO-06)			Net Change			New Budget		
			QUANTITY	UNIT PRICE	AMOUNT	QUANTITY	UNIT PRICE	AMOUNT	QUANTITY	UNIT PRICE	AMOUNT
0117	Removable Floodwall	LS	1	\$ 120,000.00	\$ 120,000.00	0	\$ -	\$ -	1	\$ 120,000.00	\$ 120,000.00
0118	F&I Floodwall Reinf Bars - Steel	LB	63,445	\$ 1.10	\$ 69,789.50	0	\$ -	\$ -	63,445	\$ 1.10	\$ 69,789.50
0119	F&I Floodwall Reinf Bars - Epoxy Coated Steel	LB	59,852	\$ 1.30	\$ 77,807.60	0	\$ -	\$ -	59,852	\$ 1.30	\$ 77,807.60
0120	F&I Floodwall - Structural Conc	CY	828	\$ 1,100.00	\$ 910,800.00	0	\$ -	\$ -	828	\$ 1,100.00	\$ 910,800.00
0121	F&I Floodwall - Misc.	LS	1	\$ 225,000.00	\$ 225,000.00	0	\$ -	\$ -	1	\$ 225,000.00	\$ 225,000.00
0122	Demolition Pump Stations, Storm Sewers, Force Mains	LS	1	\$ 110,000.00	\$ 110,000.00	0	\$ -	\$ -	1	\$ 110,000.00	\$ 110,000.00
0123	Force Mains and Sump Pump Discharge	LS	1	\$ 600,000.00	\$ 600,000.00	0	\$ -	\$ -	1	\$ 600,000.00	\$ 600,000.00
0124	Pump Station - Structural and Architectural	LS	1	\$ 2,700,000.00	\$ 2,700,000.00	0	\$ -	\$ -	1	\$ 2,700,000.00	\$ 2,700,000.00
0125	Stormwater Pumps and Motors	LS	1	\$ 1,200,000.00	\$ 1,200,000.00	0	\$ -	\$ -	1	\$ 1,200,000.00	\$ 1,200,000.00
0126	Sump Pumps	LS	1	\$ 60,000.00	\$ 60,000.00	0	\$ -	\$ -	1	\$ 60,000.00	\$ 60,000.00
0127	Trash Racks and Miscellaneous Metals	LS	1	\$ 320,000.00	\$ 320,000.00	0	\$ -	\$ -	1	\$ 320,000.00	\$ 320,000.00
0128	Sluice Gates and Wall Thimbles	LS	1	\$ 250,000.00	\$ 250,000.00	0	\$ -	\$ -	1	\$ 250,000.00	\$ 250,000.00
0129	Generator Building - Structural and Architectural	LS	1	\$ 551,000.00	\$ 551,000.00	0	\$ -	\$ -	1	\$ 551,000.00	\$ 551,000.00
0130	Gatewell Structural	LS	1	\$ 870,000.00	\$ 870,000.00	0	\$ -	\$ -	1	\$ 870,000.00	\$ 870,000.00
0131	Gatewell - Miscellaneous Metals	LS	1	\$ 100,000.00	\$ 100,000.00	0	\$ -	\$ -	1	\$ 100,000.00	\$ 100,000.00
0132	Sheetpiling (Pump Station)	LS	1	\$ 1,200,000.00	\$ 1,200,000.00	0	\$ -	\$ -	1	\$ 1,200,000.00	\$ 1,200,000.00
0133	Health and Safety	LS	1	\$ 165,000.00	\$ 165,000.00	0	\$ -	\$ -	1	\$ 165,000.00	\$ 165,000.00
0134	Diesel Generator	LS	1	\$ 385,000.00	\$ 385,000.00	0	\$ -	\$ -	1	\$ 385,000.00	\$ 385,000.00
0135	Switchboard SWBDA, Motor Control Center MCLA, Automatic Transfer Switch, Panel HP1	LS	1	\$ 280,000.00	\$ 280,000.00	0	\$ -	\$ -	1	\$ 280,000.00	\$ 280,000.00
0136	Electrical-Interior	LS	1	\$ 105,000.00	\$ 105,000.00	0	\$ -	\$ -	1	\$ 105,000.00	\$ 105,000.00
0137	Electrical-Exterior	LS	1	\$ 138,066.65	\$ 138,066.65	0	\$ -	\$ -	1	\$ 138,066.65	\$ 138,066.65
0138	Instrumentation and Controls	LS	1	\$ 25,000.00	\$ 25,000.00	0	\$ -	\$ -	1	\$ 25,000.00	\$ 25,000.00
0139	Programming	LS	1	\$ 4,300.00	\$ 4,300.00	0	\$ -	\$ -	1	\$ 4,300.00	\$ 4,300.00
0140	HVAC - General	LS	1	\$ 20,000.00	\$ 20,000.00	0	\$ -	\$ -	1	\$ 20,000.00	\$ 20,000.00
0141	Plumbing General	LS	1	\$ 9,570.00	\$ 9,570.00	0	\$ -	\$ -	1	\$ 9,570.00	\$ 9,570.00
0142	Generator Accessories, Fuel Storage and Fuel System	LS	1	\$ 156,200.00	\$ 156,200.00	0	\$ -	\$ -	1	\$ 156,200.00	\$ 156,200.00
0143	Plug Pipe 30" Dia.	EA	1	\$ 860.00	\$ 860.00	0	\$ -	\$ -	1	\$ 860.00	\$ 860.00
0144	F&I Curb & Gutter Standard (Type I)	LF	281	\$ 43.00	\$ 12,083.00	0	\$ -	\$ -	281	\$ 43.00	\$ 12,083.00
0145	F&I Grooved Plastic Film 8" Wide	LF	224	\$ 13.00	\$ 2,912.00	0	\$ -	\$ -	224	\$ 13.00	\$ 2,912.00

WP-42A.1/A.3
4th Street Pump Station and Gatewell - 2nd Street Floodwall South

Change Order 9 Unit Price Schedule
 DATE: 1/11/2016



WP-42A.1/A.3 - 4th Street Pump Station and Gatewell - 2nd Street Floodwall South											
ITEM	DESCRIPTION	UNIT	Current Budget (thru CO-06)			Net Change			New Budget		
			QUANTITY	UNIT PRICE	AMOUNT	QUANTITY	UNIT PRICE	AMOUNT	QUANTITY	UNIT PRICE	AMOUNT
0146	F&I Pipe 15" Dia Reinf Conc	LF	18	\$ 82.31	\$ 1,481.58	0	\$ -	\$ -	18	\$ 82.31	\$ 1,481.58
0147	Warming House Electrical Service	LS	1	\$ 49,834.89	\$ 49,834.89	0	\$ -	\$ -	1	\$ 49,834.89	\$ 49,834.89
0148	Bore 36" Pipe	LS	1	\$ 80,566.24	\$ 80,566.24	0	\$ -	\$ -	1	\$ 80,566.24	\$ 80,566.24
0149	Plug Pipe 6" Dia	EA	3	\$ 439.69	\$ 1,319.07	0	\$ -	\$ -	3	\$ 439.69	\$ 1,319.07
0150	F&I Flared End Section 48" Dia Reinf Conc	EA	1	\$ 5,119.28	\$ 5,119.28	0	\$ -	\$ -	1	\$ 5,119.28	\$ 5,119.28
0151	Connect Water Service	EA	2	\$ 2,643.38	\$ 5,286.76	0	\$ -	\$ -	2	\$ 2,643.38	\$ 5,286.76
0152	F&I Pipe 1" Dia Copper	LF	124	\$ 49.35	\$ 6,119.40	0	\$ -	\$ -	124	\$ 49.35	\$ 6,119.40
0153	F&I Pipe w/GB C900 DR 18 - 6" Dia PVC	LF	80	\$ 193.20	\$ 15,456.00	0	\$ -	\$ -	80	\$ 193.20	\$ 15,456.00
0154	Special Order Asbestos Fittings	EA	1	\$ 5,484.57	\$ 5,484.57	0	\$ -	\$ -	1	\$ 5,484.57	\$ 5,484.57
0155	Unknown Structures	LS	1	\$ 87,262.68	\$ 87,262.68	0	\$ -	\$ -	1	\$ 87,262.68	\$ 87,262.68
0156	CO-01 Field Changes	LS	1	\$ 14,998.89	\$ 14,998.89	0	\$ -	\$ -	1	\$ 14,998.89	\$ 14,998.89
0157	CO-02 Misc Requirements	LS	1	\$ 15,394.85	\$ 15,394.85	0	\$ -	\$ -	1	\$ 15,394.85	\$ 15,394.85
0158	Fargo Highrise Work	LS	1	\$ 6,362.42	\$ 6,362.42	0	\$ -	\$ -	1	\$ 6,362.42	\$ 6,362.42
0159	CO-04	LS	1	\$ 15,174.67	\$ 15,174.67	0	\$ -	\$ -	1	\$ 15,174.67	\$ 15,174.67
0160	Sanitary Overflow Connection	LS	1	\$ 10,363.71	\$ 10,363.71	0	\$ -	\$ -	1	\$ 10,363.71	\$ 10,363.71
0161	T&M Budget for Asbestos Pipe and Unsuitable Material Removal	LS	1	\$ 140,000.00	\$ 140,000.00	0	\$ -	\$ -	1	\$ 140,000.00	\$ 140,000.00
0162	CO-06	LS	1	\$ 67,079.47	\$ 67,079.47	0	\$ -	\$ -	1	\$ 67,079.47	\$ 67,079.47
0163	CO-07	LS	1	\$ 7,689.91	\$ 7,689.91	0	\$ -	\$ -	1	\$ 7,689.91	\$ 7,689.91
0164	Reprogramming Display	LS	1	\$ 1,386.00	\$ 1,386.00	0	\$ -	\$ -	1	\$ 1,386.00	\$ 1,386.00
0164	CO-09	LS	1		\$ -	0	\$ 12,506.80	\$ 12,506.80	1	\$ 12,506.80	\$ 12,506.80
42A.1/A.3 - TOTAL AMOUNT			CURRENT BUDGET		\$ 18,038,757.39	NET CHANGE		\$ 12,506.80	NEW BUDGET		\$ 18,051,264.19



P.O. Box 13158 • Grand Forks, ND 58208-3158
(P) 701.775.8480 (F) 701.775.8479
www.icsgf.com

01/03/17

CH2M
Attn: Tyler Smith
64 4th St. N.
Fargo, ND 58102

**Re: In-Town Levees 2nd Street/Downtown Area-Phase 42A.1/42A.3 Work Package 42A.1/42A.3
Adding Fuel Tank Sensors**

Mr. Smith,

The attached costs are to add level sensors to the fuel storage tank. The added sensors will monitor the 25%, 50% and 75% fuel levels in the fuel tank.

DESCRIPTION	U.M.	UNITS	UNIT PRICE	EXT. PRICE
Fuel Tank Sensors	LS	1.00	\$1,906.80	\$1,906.80
			TOTAL PRICE:	\$1,906.80

The level sensors will be added per the attached quote from Fusion Automation OPTION A. The proposed sensor information is also attached to this quote.

If you have any questions regarding the above, please contact me at your earliest convenience.
Sincerely,

Gary Beeter
ICS, Inc.
Vice President

Cc: Peter Chitwood/CH2M



CHANGE ORDER PROPOSAL # E20

DATE: NOVEMBER 30TH, 2016

PROJECT: FARGO 4TH STREET PUMP HOUSE FLOOD RISK MANAGEMENT

SUMMARY: ADDITIONAL TANK READING LEVELS

Additional sensor to monitor 25%, 50% and 75% fuel levels in fuel tank like 2nd street.

OPTION A: HTF 3 float stem sensor

- Only measures 3 set levels
- Electronic feedback
- Labor for Install

TOTAL \$1,816.00

OPTION B: Deep Product Level Gauge

- Direct Reading Gauge
- High Density Polyethylene Plastic Float
- Measures fuel level from 0% to 100% full
- No PLC control; No electronic feedback

TOTAL \$109.00

OPTION C: Clock Gauge w/Alarm

- Direct Reading Gauge
- Alarm System
- Uses floats
- No PLC control; No electronic feedback
- Labor for Install

TOTAL \$1,980.80

OPTION D: Continuous Level Sensor

- Uses float
- Measures fuel level from 0% to 100% full
- Electronic Feedback
- Explosion Proof Rated
- Labor for Install

TOTAL \$2,739.22

Anne Mayer
Fusion Automation Inc
701-757-0852
Anne.Mayer@fusionautomationinc.com

Series HTF Standard Three Float Sensor



Highland Tank

Engineering Bulletin

One Highland Road, Stoystown Pa.15563
814-893-5701 - Fax 893-6126
www.Highlandtank.com
email: staff @ highlandtank.com

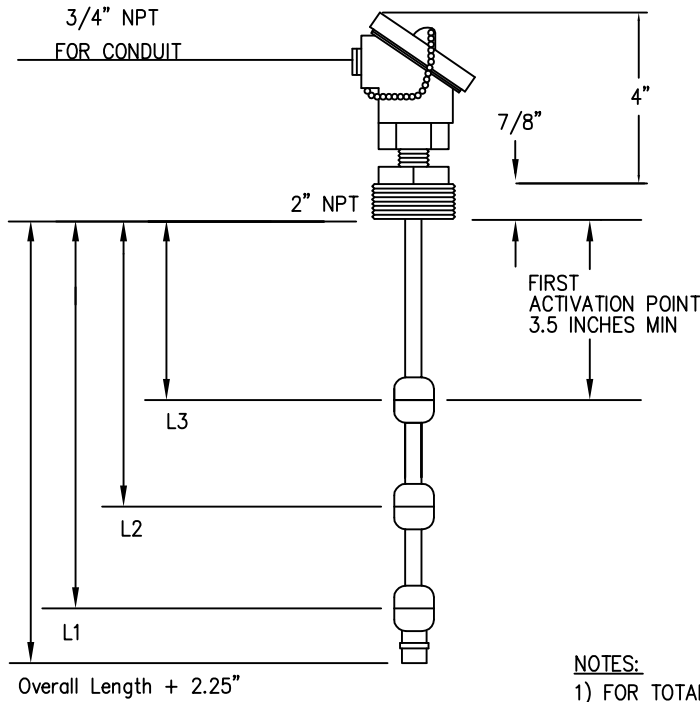
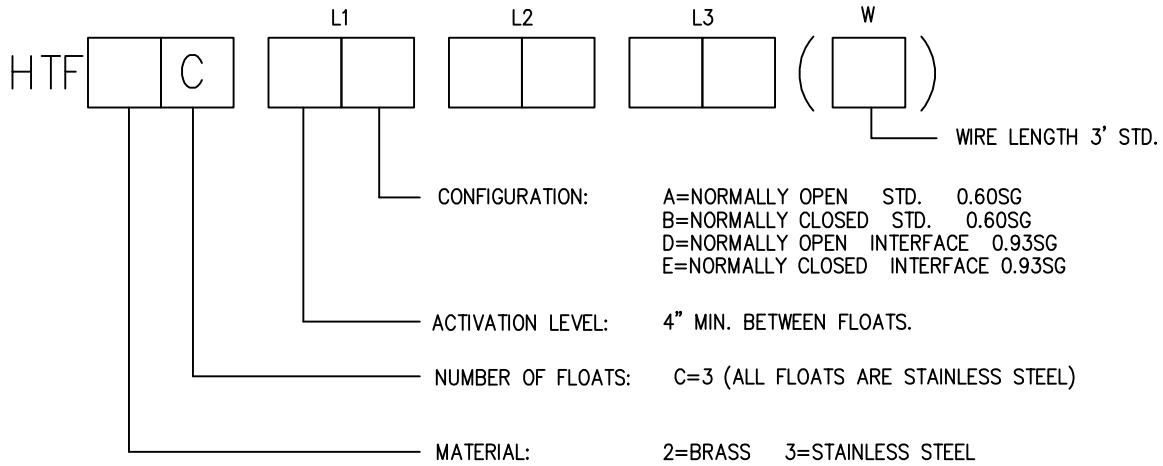

SPECIFICATIONS:

HOUSING:	CAST ALUMINUM NEMA 4X
FITTING:	BRASS OR STAINLESS STEEL
THREAD SIZE* :	2" - 11 1/2 NPT
FLOAT SIZE:	1.85" DIA. x 3.01" HIGH
CONTACT RATING:	FOR INTRINSICALLY SAFE CONTROL CIRCUIT ONLY
STEM SIZE:	1/2"
SPECIFIC GRAVITY:	0.6 STANDARD 0.93 INTERFACE
WIRE COLOR CODE FOR 10' OR LESS :	L1=RED L2=YELLOW L3=BLUE
WIRE COLOR CODE FOR GREATER THAN 10' :	L1 = RED & BLACK L2 = GREEN & WHITE L3 = BLUE & BROWN

NOTES:

- 1) FOR TOTAL LENGTHS OVER 8 FEET, CONTACT HIGHLAND TANK
- 2) ACTIVATION LEVEL TOLERANCE +/- .125"
- 3) CONSULT FACTORY FOR OPTIONAL MOUNTING OPTIONS

Option B



KRUEGER SENTRY GAUGE®

Direct Reading Gauge—Type D

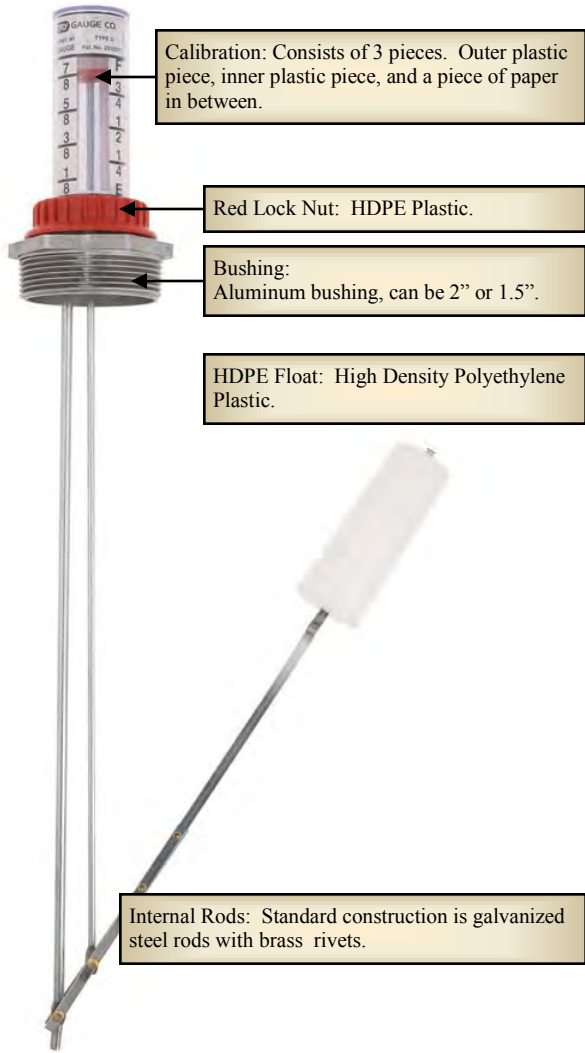

Part Number—
D-(size opening)-(tank depth)+(ext)-(list options)
Sample—D-2-48+12

What it is:

Top mounted liquid level gauge that can measure from 6 inches to 144 inches in depth. Bushing size can be 2", 1.5", or .75". Gauges are custom made in house to fit your tank. Can also accommodate for double walls and pipe risers.

Additional Options - Not included:

Audible Alarm Accessory: This add on feature can turn your mechanical gauge into an audible Hi or Lo level alarm.

LED At-A-Glance Accessory: Another add on feature. This can give your mechanical gauge remote reading capability.

Gauge Guard: A cover that protects the exposed plastic components on top of the gauge.

Replacement Parts -

D-Kit - Replaces all of the gauge components from the red lock nut and up. Includes: Red HDPE Plastic Nut, Duro Nitrile Gasket, Plastic Cellulose acetate inner and outer calibration.

DG-Kit-ALN - Replaces all of the gauge components from the red lock nut and up with upgraded parts. Includes: Aluminum Lock Nut, Duro Nitrile Gasket, Plastic Cellulose acetate outer calibration, Glass inner calibration.

Instructions for Operation:

This gauge is a simple volume reading tool. The top of the red indicator is an indication of your approximate fuel level in your tank. Once installed, you simply view the calibration to monitor your tank level. Indicator is calibrated in eighths of a tank on one side, and quarters of a tank on the other.

Krueger Sentry Gauge
1873 Siesta Lane
Green Bay, WI 54313

www.ksentry.com



Contact us for more info:
Ph: 920-434-8860
Fax: 920-434-8897

Email: info@ksentry.com

Model 918 Clock Gauge and Alarm Series

SPECIFICATION SHEET

The Morrison “clock gauge” displays the liquid level of product stored in an aboveground storage tank. Measures the liquid level in tanks up to 12 feet high. The 918 audible alarm sounds when the liquid level in the tank reaches the user’s specified level.

Gauge features

- Easy to install in a single 2” tank top opening, easy to calibrate
- Gauge face displays level reading in feet and inches. The hour hand (short hand) displays the number of feet and the minute hand (long hand) accurately displays the number of inches
- Gallon or liter reading gauge models available
- Accurate to 1/8 of an inch
- Easily read from 30 feet away
- Vapor tight construction and fog free design
- Gauge rotates 360° making it easy for the face to be read from the desired orientation
- Visual indicators for high level (red) and low level (green)
- Floats fit through a 2” schedule 40 pipe nipple; reduces float entanglement when turbulent conditions are present
- **918T and 918FT** series are compatible for use with Diesel Exhaust Fluid (DEF)

The 918 alarm box can be paired with a variety of Morrison 918 clock gauges or level sensors. Alarm set point calibrated at installation. The alarm box is compliant with UL 913 and CSA 157 intrinsic safety standards.

Alarm features

- Audible and visual indicators
- Self-powered by long-life replaceable lithium batteries
- Monitor up to four sensor signals
- User-defined alarm labels
- Visual alarm indicators easily identify which sensor is alarming
- Compatible with 918/918 TCP gauging equipment
- Low battery visual indicator
- Audible alarm sounds 90 dB alarm at four feet away
- Modular contacts make alarm devices easy to install
- In compliance with UL 913 and CSA 157 intrinsic safety standards
- Corrosion-resistant and water-resistant housing for long life
- Intrinsically safe for Class I, Division 1 and 2, Group D hazardous location



Option C

Model 918 Clock Gauge and Alarm (continued)

Alarm features (continued)

- Audible alarm auto silence mode (10 minutes)
- **918/918F** clock gauge with 918S, 918D, or 918Q alarms are Florida DEP EQ527 approved



I.D. Number	A	B	C	D	E	F	G	H	I.D. Number	A	B	C	D	E	F	G	H
918---0000 AG	N	M	ST	S	8.42	3.48	6.06	6.25	918MET0100 AG	Y	M	ST	M	8.42	3.48	6.06	7.45
918---0000AGEVR	N	M	ST	S	8.42	3.48	6.06	6.25	918MET0400 AG	Y	M	DT	M	8.42	3.48	6.06	7.45
918---2000 AG	N	M	DT	S	8.42	3.48	6.06	6.25	918T--0400 AG	Y	M	DT	S	8.42	3.48	6.06	7.45
918---2000AGEVR	N	M	DT	S	8.42	3.48	6.06	6.25	918T--2000 AG	N	M	DT	S	8.42	3.48	6.06	7.45
918C--0000 AG	N	M	ST	C		3.48	6.06	6.25	918FT-0400 AG	Y	F	DT	S	9.62	3.48	6.06	7.95
918C--2000 AG	N	M	DT	C		3.48	6.06	6.25	918FT-2000 AG	N	F	DT	S	9.62	3.48	6.06	7.95
918CF-0000 AG	N	F	ST	C		3.48	6.06	6.25	918MEFT400 AG	Y	F	DT	M	9.62	3.48	6.06	7.95
918CF-2000 AG	N	F	DT	C		3.48	6.06	6.25	918METT400 AG	Y	M	DT	M	8.42	3.48	6.06	7.45
918--0100 AG	Y	M	ST	S	8.42	3.48	6.06	7.45	918S--1000 AA	Y	Single channel tank alarm box only						1.80
918--0400 AG	Y	M	DT	S	8.42	3.48	6.06	7.45	918D--1000 AA	Y	Dual channel tank alarm box only						1.80
918C--0100 AG	Y	M	ST	C		3.48	6.06	6.25	918Q--1000 AA	Y	Quad channel tank alarm box only						1.80
918C--0100 AG	Y	M	DT	C		3.48	6.06	6.25	<p style="text-align: center;">SPECIFICATION OPTIONS:</p> <p>A—Overfill Alarm Box: Included: Yes/No B—Body Connection: Male (M), Female (F), BSP (B) C—Float Device: Standard 2" Float (ST), Drop Tube Float (DT) D—Face Plate: Standard (S), Metric (M), Custom (C) E—Gauge height: (Inches) F—Gauge width: (Inches) G—Clock Diameter: (Inches) H—Shipping Weight (lbs.)</p>								
918CF-0400 AG	Y	F	ST	C		3.48	6.06	6.25									
918CF-0400 AG	Y	F	DT	C		3.48	6.06	6.25									
918F--0100 AG	Y	F	ST	S	9.62	3.48	6.06	7.95									
918F--0400 AG	Y	F	DT	S	9.62	3.48	6.06	7.95									
918F--0000AGEVR	N	F	ST	S	9.62	3.48	6.06	6.25									
918F--2000AGEVR	N	F	DT	S	9.62	3.48	6.06	6.25									
918MEB0100 AG	Y	M B	ST	M	8.42	3.48	6.06	7.45									
918MEB0400 AG	Y	M B	DT	M	8.42	3.48	6.06	7.45									
918MEF0000AGEVR	N	F	ST	M	8.42	3.48	6.06	7.95									
918MEF2000AGEVR	N	F	DT	M	8.42	3.48	6.06	6.25									
918MEF0100 AG	Y	F	ST	M	9.62	3.48	6.06	7.95									
918MEF0400 AG	Y	F	DT	M	9.62	3.48	6.06	7.95									
918MET0000AGEVR	N	M	ST	M	8.42	3.48	6.06	6.25									
918MET2000AGEVR	N	M	DT	M	8.42	3.48	6.06	6.25									

570 E. 7th Street, P.O. Box 238 | Dubuque, IA 52004-0238
t. 563.583.5701 | 800.553.4840 | f. 563.583.5028

CONTINUOUS LEVEL

Technical Specifications

Model:	XT-800
Specific Gravity:	.82
Max. Pressure:	30
Stem Length:	Up to 72"
Stem Construction:	Tubing (for units < 72")
Operating Temp.:	80
Stem Material:	316 Stainless Steel
Mounting Type:	(3) 2" NPT
Termination:	Junction Box
Output:	4 - 20mA
Float Material:	316 Stainless Steel
Float Type:	316 Stainless Steel (156490)
Media Type:	Diesel
Float Stops:	Grip Rings
Explosion Proof:	FM Approved Explosion Proof

Ordering Information

Part Number:	
List Price:	
Lead Time:	
Min. Order Quantity:	
Shipping Weight:	
Model Description:	

Dimensional Specifications

Indicating Length:	56.5"
C Dimension:	1.25"
Overall Length(B Dimension):	61

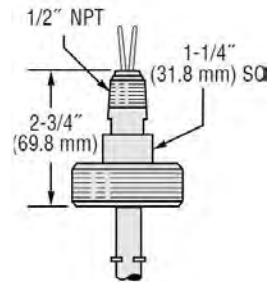
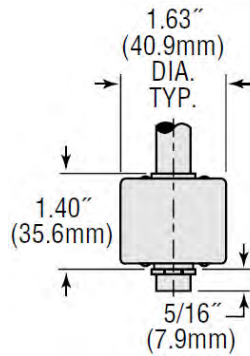
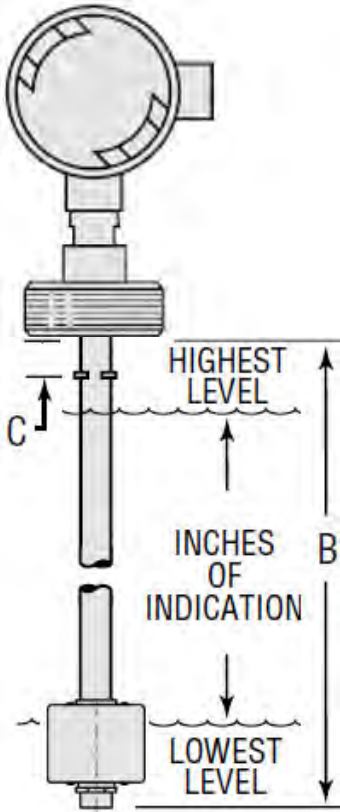

Small Size – Alloys

XM/XT-800 Series – Compact Analog Sensors

- ▶ Stainless or Brass Construction
- ▶ 1/4" Resolution
- ▶ Lengths to 144 inches (366 cm)
- ▶ OEM Configurations Available

These compact transmitters feature the rugged durability of stainless steel or brass construction. The XM-800 series provides analog output, and can be combined with GEMS Digital Meter Receiver Stations and compact Level Cubes described in this catalog. Our versatile XT-800 Series adds a choice of signal conditioning for use with GEMS digital bargraph receivers or other digital display and control equipment.

Approvals

XM-800 and XT-800 Series transmitters may carry the following commercial approvals:

- FM Approved, Explosion-Proof (J-Box and Stainless Steel Float required).
- UL-Recognized.

XM-800 Series transmitters only:

- CSA Certified

XT-800 Series transmitters only:

- FM Approved, Intrinsic Safety (J-Box and Stainless Steel Float required).

1. Mounting Types

Type 1 1/2" NPT	Type 2 1-1/4" NPT	Type 3 2" NPT	Type 4 3" 150# Flange	Type 6 2-1/2" Sanitary Flange

Stem Material	Brass or 316 Stainless Steel	316 Stainless Steel	
Mounting Material	Brass or 316 Stainless Steel	Carbon Steel or 316 Stainless Steel	316 Stainless Steel
Float Stop Material	Brass Units: Beryllium Copper Grip Rings; Stainless Steel Units: S.S. ARMCO PH-15-7MO Grip Rings		
Operating Temperature* With J. Box Mounted or XM Signal Conditioners	Oil: -40°F to +230°F (-40°C to 110°C), Water to +180°F (82.2°C)—Buna N Float -40°F to +230°F (-40°C to 110°C)—Stainless Steel Float		
With Stem Mounted Signal Conditioners	+5°F to +160°F (-15°C to +70°C)		
Operating Pressure	Dependent on Float Type; See Next Page		
Overall Length, Max.	72" (183 cm) Tubing; 144" (366 cm) Pipe (Types 3 & 4 only)		

* Consult factory for higher temperature ranges.

ORDER IT!

Ordering is Easy! See Page C-5.
Easy online ordering too!

Lengths
to 12 ft!



2. Float Types

Based on the overall length required by your tank, select from two main subsets of floats below; further refine selection based on material and performance parameters.

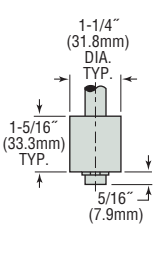
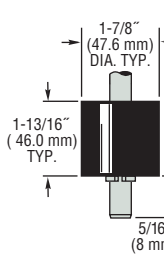
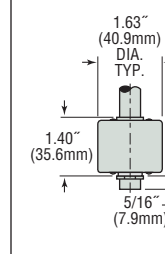
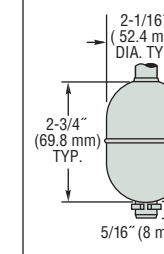
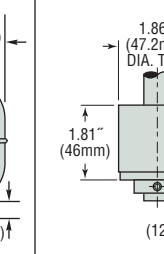
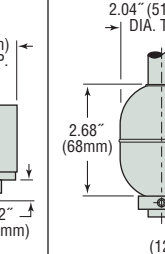
Float Material	For Overall Lengths To 72"				For Lengths Greater Than 72" (144" Max.)	
	Buna N		Stainless Steel		Buna N	Stainless Steel
Float Dimensions						
Compatible Mountings	1, 2, 3, 4, 6	1, 3, 4	1, 3, 4, 6	1, 3, 4	3, 4	3, 4
Part Number	164255²	43359	156490	43590	69654	52084
Min. Liquid Spec. Gravity	.55	.55	.70	.75	.55	.75
Operating Pressure, Max.¹	150 psi (10 bar)	150 psi (10 bar)	80 psi (6 bar)	300 psi (21 bar)	150 psi (10 bar)	300 psi (21 bar)
Operating Temp., Max.	Water: 180°F (82°C) Oil: 230°F (110°C)		230°F (110°C) ³		Water: 180°F (82°C) Oil: 230°F (110°C)	230°F (110°C)*

Notes:

- @ Ambient Temperature
- Recommended for Type 2 mounting only.
- Consult factory for higher temperature range.

3. To Determine Dimensions

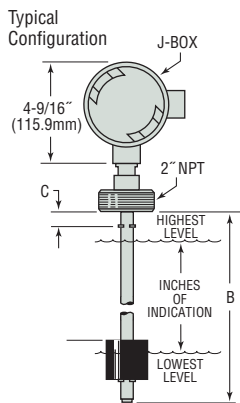

- B: Overall Length = Inches of Indication + C + X (See Table at Right)
 C: Distance From Bottom of Mounting to Float Stop (Customer Specified):
- 1/4" (6.4mm) Minimum
 - 1-1/4" (31.8mm) Minimum on Type 1, XT Series only.

Calculating Length

- To find Overall Length when Inches or Indication is known:
 • Inches of Indication + C* + X = Overall Length
- To find Maximum Inches of Indication when Overall Length is known:
 • Overall Length - C* - X = Maximum Inches of Indication

*C dimension is determined by customer.

Float Factor – X

Float Part Number	X
164255	2.0" (50.8)
43359	2.5" (63.5)
156490	2.062" (52.4)
43590	3.437" (87.3)
69654	2.687" (68.3)
52084	3.625" (92.1)

Inch (mm)

4. Input/Output

For XM-800 Series, no special output designation is necessary.
 For XT-800 Series, specify the desired signal conditioning by Part Number.
 Additional information about GEMS signal conditioning modules is found on Page C-16.

Series	Input Voltage	Output Signal	Part Number	Electrical Termination	Compatible Mountings		
					Type 1	Type 3	Type 4
XM-800	10 to 30 VDC	Proportional Voltage	—	Lead Wires (3), #22 AWG, 24" (60.9 cm), PTFE Jacket	•	•	•
	8 to 24 VDC*	0-5 VDC	51965	Lead Wires, #22 AWG, 24" (60.9 cm), PTFE Jacket	•	•	•
XT-800	14 to 30 VDC*	0-12 VDC	51970		•	•	•
	8 to 24 VDC*	0-5 VDC	52536	Junction Box		•	•
	15 to 30 VDC*	0-12 VDC	52537			•	•
	10 to 40 VDC	4-20 mA	52555	Panel Mount with Plug-in Base		•	•
	4-20 mA	112300	•		•	•	

* Stem mounted.

 <p>Photocopy This Form Use one form for each product type you are selecting. <small>This form may also be completed online at gemssensors.com for RFQ.</small></p>	This is a <input type="checkbox"/> Request for a Quote Name _____ <input type="checkbox"/> Order P.O.# _____ Company _____ Quantity Needed _____ Street _____ Date Required ____/____/____ City _____ State ____ Zip _____ Shipping Method: _____ Phone (____) _____ Partial Accepted: <input type="checkbox"/> Yes Fax (____) _____ <input type="checkbox"/> No
--	--

Float Type Level Transmitters – XM/XT-800 Series

Application Environmental Conditions

This information is essential to the accurate and proper operation of your GEMS configurable sensors. Please complete fully and accurately.

- 1. Liquid Media:** _____
- 2. Pressure:** Minimum _____ psig Maximum _____ psig
- 3. Temperature:** Minimum _____ °F Maximum _____ °F
- 4. Specific Gravity:** Minimum _____ Maximum _____

- 5. Viscosity:** _____ SSU
- 6. Tank Material:** _____
Tank Depth: _____
- 7. Unit is Mounted In:** Tank Top Tank Bottom
- 8. Moisture Protection Required?** Yes No

1. Series:

- XM/XT-800 (1/4" Resolution)

2. Mounting Type:

- Type 1 (1/2" NPT) Type 2 (1-1/4" NPT) Type 3 (2" NPT)
 Type 4 (3" 150# flange) Type 6 (2-1/2" sanitary flange)

3. Materials:

- a. Stem:
 Brass¹ 316 Stainless Steel
- b. Mounting:
 Brass¹ 316 Stainless Steel
 Carbon Steel (Type 4 flange only)
- c. Collar Float Stops²:
 Brass 316 Stainless Steel

4. Float Type¹:

Match to Overall Length of Transmitter Stem

To 72 Inches	Over 72 Inches
<input type="checkbox"/> 164255 – Buna N ²	<input type="checkbox"/> 69654 – Buna N
<input type="checkbox"/> 43359 – Buna N	<input type="checkbox"/> 52084 – Stainless Steel
<input type="checkbox"/> 156490 – Stainless Steel	
<input type="checkbox"/> 43590 – Stainless Steel	

Notes:

1. Stainless Steel float required for FM Approved Explosion Proof units.
 2. Recommended for Type 2 mounting.

Notes:

1. Type 1, Type 2 and Type 3 only
 2. Standard Float Stops supplied in PH 15-7 MO on S.S. units and Beryllium Copper on Brass units. Brass and S.S. Float Stops with Brass and S.S. units only, respectively.

5. Dimensions:

Overall Length (complete one line only):

Float Selected	Indicating Length (Half Inches)	+	"C" Dimension ±1/16" (1.8 mm)	+	Float Factor X Inch (mm)	=	Overall Length
43359		+		+	2.5 (63.5)	=	
43590		+		+	3.44 (87.3)	=	
52084		+		+	3.63 (92.1)	=	
69654		+		+	2.69 (68.3)	=	
156490		+		+	2.06 (52.3)	=	
164255		+		+	2 (50.8)	=	

Notes:

1. Indicating Length: 1/2" increments
 2. Minimum C Dimension = 1/4"; or 1/2" on units greater than 72" in length.

7. Options:

- Explosion Proof J-Box* NEMA 4 J-Box

* Required for FM Approved Explosion Proof units

Please contact Gems for any configuration or special requirements not covered on this form. **800-378-1600**

Quote: \$ _____ Date Quoted: ____/____/____

6. Input/Output:

- a. Optional 24 VDC Power Supply:
 115 VAC input 230 VAC input
- b. Signal Conditioners (XT-800 Series Only)
 Output Shown in Parenthesis:
 51965 (0-5 VDC – stem)
 51970 (0-12 VDC – stem)
 52536 (0-5 VDC – J-box)
 52537 (0-12 VDC – J-box)
 52555 (4-20 mA – J-box)
 120650 (0-5 VDC – panel mount)
 149600 (0-10 VDC – panel mount)
 112300 (4-20 mA – panel mount)



Gems Sensors & Controls
 One Cowles Road
 Plainville, CT
 06062-1198

tel 860.747.3000
 fax 860.747.4244
www.gemssensors.com



P.O. Box 13158 • Grand Forks, ND 58208-3158
(P) 701.775.8480 (F) 701.775.8479
www.icsgf.com

01/03/16

CH2M
Attn: Tyler Smith
64 4th St. N.
Fargo, ND 58102

**Re: In-Town Levees 2nd Street/Downtown Area-Phase 42A.1/42A.3 Work Package 42A.1/42A.3
Floodwall Coping Caps**

Mr. Smith,

The attached cost is for a design change to the floodwall coping for the south end of the floodwall. The request for pricing the change was from HMG.

DESCRIPTION	U.M.	UNITS	UNIT PRICE	EXT. PRICE
Material	LS	1.00	\$4,205.00	\$4,205.00
TOTAL PRICE:				\$4,205.00

The City of Fargo has been adding a higher pitched floodwall coping to detour climbing on the floodwalls. The price is to all the taller wall caps to the wall south of the closure on 2nd street only. This project did not call for that design originally. The pricing above is to procure the new coping, offload onsite, and remove the original coping from site.

If you have any questions regarding the above, please contact me at your earliest convenience.
Sincerely,

Gary Beeter
ICS, Inc.
Vice President

Cc: Peter Chitwood/CH2M

01/05/17

CH2M
Attn: Tyler Smith
64 4th St. N.
Fargo, ND 58102

**Re: In-Town Levees 2nd Street/Downtown Area-Phase 42A.1/42A.3 Work Package 42A.1/42A.3
Trash Rack Mods**

Mr. Smith,

The attached cost is for a design change to the Trash Rack Rake System in the pump station. Glen Krogman with HMG requested the change so that the trash racks would operate smoother.

DESCRIPTION	U.M.	UNITS	UNIT PRICE	EXT. PRICE
Material	LS	1.00	\$1269.00	\$1269.00
Labor	LS	1.00	\$5124.00	\$5124.00
TOTAL PRICE:				\$6393.00

The trash rack rake modifications were requested by HMG to improve functionality. Glen Krogman with HMG provided a sketch dated 12-07-16 showing the changes and is the basis for our pricing. It is our understanding that the design was based on a prototype that operated in the field. This price includes materials, labor for installation, as well as labor to help Glen in the field with fitting his prototypes.

If you have any questions regarding the above, please contact me at your earliest convenience.
Sincerely,



Eric Bye
ICS, Inc.
Project Manager

Cc: Peter Chitwood/CH2M



Project: 42A1 42A3

Computed: *[Signature]*

Date: 12-7-16

Subject: 4th St Pump Sta

Checked:

Date:

Task: Trash Rack Adjustment

Page:

of:

Job #:

No:

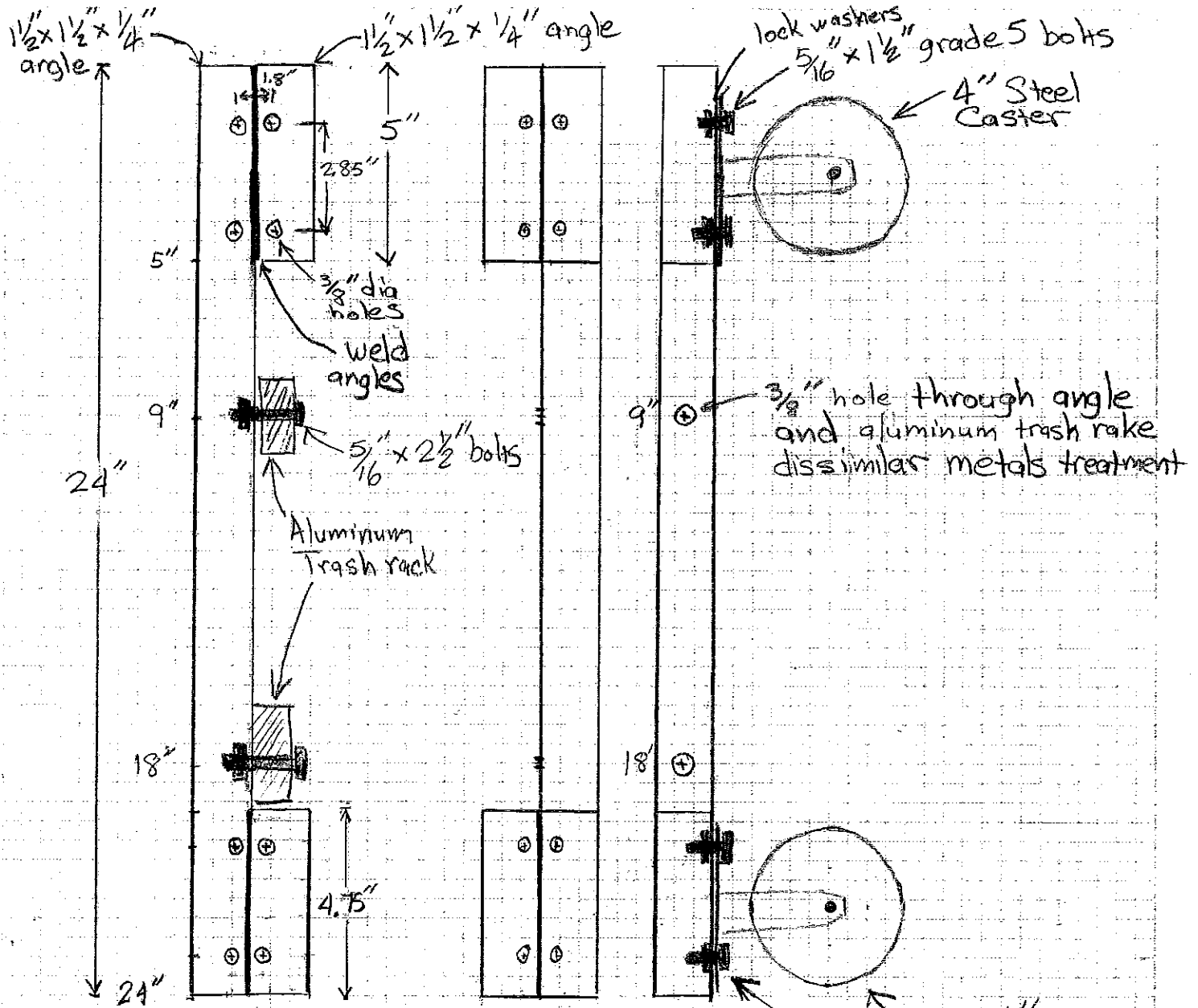

4 pieces galvanized

4 pieces galvanized

- 16 - 4" casters
100018 STF-04RSC
- 64 - 5/16" grade 5
- 16 - 1 1/2" long
- 80 - 2 1/2" long bolts
- 64 - 5/16" nuts
- 80 - 5/16" lock washers

Casters are from Mac's Hardware per Glen Krogman

zinc coated
B20
J 203